

DOUGLAS COUNTY, KANSAS

DEPARTMENT OF PUBLIC WORKS

UTILITY INSTALLATION STANDARDS

2016

[www.douglascountyks.org](http://www.douglascountyks.org)

# DOUGLAS COUNTY, KANSAS

## DEPARTMENT OF PUBLIC WORKS

### UTILITY INSTALLATION STANDARDS

2016

#### **CERTIFICATION**

Pursuant to the power and authority granted to the Douglas County, Kansas, Department of Public Works by Resolution 16-22, I, Keith A. Browning, P.E., Director of Public Works/County Engineer declare that the Douglas County, Kansas, Department of Public Works has officially adopted these Utility Installation Standards. Adherence to standards and the regulation of the use of road right-of-way on the Douglas County Highway System is to be authorized through the issuance of Utility Permits or Reimbursable Utility Agreements.

Dated this 26 day of September, 2016.

/S/ Keith A. Browning  
Keith A. Browning, P.E.  
Director of Public Works/County Engineer

## TABLE OF CONTENTS

	PAGE
INTRODUCTION.....	5
GLOSSARY OF TERMS / DEFINITIONS.....	6
<b>PART ONE GENERAL REQUIREMENTS</b>	
I. GENERAL PROVISIONS.....	11
II. PERMITS.....	13
III. PROTECTION OF TRAVELING PUBLIC.....	14
IV. DESIGN CONSIDERATIONS.....	15
V. MAINTENANCE AND SERVICING OF UTILITIES.....	15
VI. PRESERVATION, RESTORATION, AND CLEANUP.....	16
VII. SPRAYING, CUTTING AND TRIMMING TREES.....	17
<b>PART TWO UTILITIES ON PERMITTED ROADS</b>	
I. GENERAL PROVISIONS.....	21
II. ABOVEGROUND INSTALLATIONS.....	23
III. UNDERGROUND INSTALLATIONS.....	24
IV. ENCASEMENT OF UTILITIES.....	26
<b>PART THREE ATTACHMENTS TO BRIDGES AND OTHER STRUCTURES</b>	
I. GENERAL PROVISIONS.....	33
II. PERMITTED HIGHWAYS.....	34
APPENDIX.....	38
INDEX.....	53

# INTRODUCTION

# **DOUGLAS COUNTY DEPARTMENT OF PUBLIC WORKS UTILITY INSTALLATION STANDARDS**

## **INTRODUCTION**

These standards are adopted by the Douglas County Department of Public Works acting pursuant to the authority granted by the Board of County Commissioners and the State of Kansas to establish and administer the Douglas County Highway System.

The power and authority of the Director of Public Works/County Engineer of Douglas County with respect to the accommodation of utilities are as set forth generally and principally in Kansas statutes and Douglas County Resolution 16-22. These sources of authority require compliance with state/local regulations and obtaining a permit for construction of public and private utilities (including pipelines) along, crossing over or under any county highway right-of-way. Utilities occupying public right-of-way involved in road construction projects are issued a use permit by the county. Any agreement for use of highway right-of-way is to include a statement as to which party will bear the cost of future adjustments or relocations required as a result of street or highway improvements.

If applicable statute, rule or regulation sets forth more stringent requirement than these Utility Installation Standards, the statute, rule or regulation shall control.

These standards become effective upon the certification date and supersede all previously published Douglas County standards for accommodating utility facilities and appurtenances on highway right-of-way.

If application of these standards is not feasible, alternate proposals may be submitted by the Utility Company to the County Engineer for consideration.

The County Engineer reserves the right to waive the provisions of these Utility Installation Standards.

## **GLOSSARY OF TERMS / DEFINITIONS**

**BACKFILL:** Replacement of soil around and over an underground Utility Company facility.

**BORING:** Piercing a hole under the surface of the ground without disturbing the earth surrounding the hole. Boring may be accomplished by any Douglas County approved manner. Water jetting or puddling is not permitted. Holes may be mechanically bored and cased using a cutting head and a continuous auger mounted inside of the casing. Small diameter holes may be augured and the casing or utility facility pushed in later.

**BURY:** Placement of the Utility Company facility below grade of roadway, ditch or natural ground to a specified depth.

**CARRIER:** Pipe directly enclosing a transmitted fluid (liquid or gas).

**CASING:** A larger pipe enclosing a carrier.

**CLEAR ZONE:** The total roadside border area, starting at the edge of the traveled way, available for safe use by errant vehicles. This area may consist of a shoulder, recoverable slope, non-recoverable slope, and/or clear run-out area. The desired width is dependent upon the traffic volumes and speeds, and the roadside geometry.

**COATING:** Material applied to or wrapped around a pipe.

**CONDUIT OR DUCT:** An enclosed tubular runway for enclosing wires or cables.

**DIRECT BURIAL:** Installing an underground utility without encasement by plowing or trenching.

**DITCH GRADE:** Original plan grade, not silted in.

**ENCASEMENT:** Structural element surrounding a pipe or cable.

**FLEXIBLE PIPE:** A plastic, fiberglass, or metallic pipe having a large ratio of diameter to wall thickness which can be deformed without undue stress. Copper or aluminum pipe shall be considered as flexible pipe.

**GROUNDING:** Connected to earth or to some extended conducting body which serves instead of the earth whether the connection is intentional or accidental.

**GROUT:** A cement mortar or slurry of fine sand or clay.

**HIGHWAY or ROAD:** The entire area within the right-of-way dedicated as a public way for the purpose of vehicular travel.

**JACKING:** The installation of small pipes by the use of hydraulic jacks or rams to push the pipe under the traveled surface of the road.

**KDOT STANDARD SPECIFICATIONS:** Standard Specifications for State Road and Bridge

Construction. The specifications are located online at:  
[www.ksdot.org/burConsMain/specprov/specifications.asp](http://www.ksdot.org/burConsMain/specprov/specifications.asp)

**MANHOLE:** An opening to an underground utility system which workers or others may enter.

**NATURAL GAS PIPE LINES:**

**DISTRIBUTION SYSTEM:** Pipeline other than a gathering or transmission line.

**SERVICE LINE:** Distribution line that transports gas from a common source of supply to a customer meter.

**TRANSMISSION SYSTEM:** Pipeline other than a gathering line that transports gas from a gathering line or storage facility to a distribution center or storage facility. Operates at a hoop stress of 20 per cent or more of the Specified Minimum Yield Strength (SMYS).

**NORMAL:** Crossing at a right angle.

**PIPE:** A tubular product made as a production item for sale. Cylinders formed from plate in the course of the fabrication of auxiliary equipment are not pipe.

**PRESSURE:** Relative internal pressure in PSIG (Pounds per Square Inch Gauge).

**PRIVATE LINES:** Privately owned facilities which convey or transmit commodities as defined in this section but devoted exclusively to private use.

**PUBLIC LINES:** Facilities which convey or transmit commodities as defined in this section and directly or indirectly serve the public or any part thereof.

**REMEDICATION WELL:** A well installed and used for remediation of environmental pollution.

**RETAINING WALL SYSTEMS:** Retaining wall systems shall include Mechanically Stabilized Earth (MSE) Walls, Modular Block Walls (MBW), Cast-in-Place Walls, Crib Walls, T-Walls and etc.

**RIGHT-OF-WAY:** Land, property or interest therein, usually in a strip, acquired for or devoted to highway transportation purposes.

**ROAD or HIGHWAY:** The entire area within the right-of-way dedicated as a public way for the purpose of vehicular travel.

**ROADWAY:** That portion of the highway extending from outside shoulder line to outside shoulder line or between curb lines.

**SHOULDER:** That portion of roadway contiguous with the traveled way for accommodation of stopped vehicles and emergency use.

**TRAFFIC CONTROL PLAN:** A signing plan for controlling traffic when work is being performed on the highway or within the "Clear Zone". The signing plan will be in accordance with the current edition of the Manual on Uniform Traffic Control Devices. The signing plan will also

address storage of materials and parking for work crew vehicles on the right-of-way when appropriate.

**TRAVELED WAY:** The portion of the roadway for the movement of vehicles, exclusive of shoulder and auxiliary lanes.

**TRENCHED:** Installed in a narrow excavation.

**TUNNELING:** Excavating the earth ahead of a large diameter pipe by one or more of the following processes:

- 1) The earth ahead of the pipe will be excavated by men using hand tools while the pipe is pushed through the holes by means of jacks, rams, or other mechanical devices.
- 2) The excavation is carried on simultaneously with the installation of tunnel liner plates.
- 3) The tunnel liner plates are installed immediately behind the excavation as it progresses and are assembled completely from the inside.

**UTILITIES:** All privately, publicly or cooperatively owned lines, facilities and systems for producing, transmitting or distributing communications, power, electricity, light, heat, gas, oil, crude products, water, steam, waste, storm water, and other similar commodities, including fire and police signal systems and street lighting systems which directly or indirectly serve the public.

**UTILITY COMPANY AND ROW OCCUPANT:** Utility Company is a Company placing their utility on County's right-of-way. ROW occupant is anyone who is utilizing County's right-of-way for placement of utility or other approved item.

**UTILITY PERMITS:** Executed for all Utility Company facilities located on highway right-of-way.

**REIMBURSABLE UTILITY AGREEMENTS:** Executed when Utility Company facilities are located on private right-of-way and must be relocated for highway improvements.

**WALL SYSTEM:** refer to Retaining Wall Systems.



# **PART ONE**

## **GENERAL REQUIREMENTS**

**PART ONE  
GENERAL REQUIREMENTS**

	PAGE
I. GENERAL PROVISIONS .....	11
A. GENERAL .....	11
B. LIABILITY .....	12
C. CHANGE IN OWNERSHIP .....	12
D. ABANDON OR RETIRE IN PLACE .....	12
E. RELOCATION FOR ROAD CONSTRUCTION PROJECTS .....	12
F. DISCHARGE OF WASTE MATERIAL .....	12
G. NON-COMPLIANCE .....	12
II. PERMITS .....	13
A. GENERAL .....	13
B. APPLICATIONS .....	13
C. DOUGLAS COUNTY OFFICE .....	14
III. PROTECTION OF TRAVELING PUBLIC .....	14
A. TRAFFIC CONTROL .....	14
B. STORAGE AND PARKING .....	15
IV. DESIGN CONSIDERATIONS .....	15
A. DESIGN .....	15
B. MATERIALS .....	15
C. FUTURE EXPANSION .....	15
V. MAINTENANCE AND SERVICING OF UTILITIES .....	15
A. UTILITY OWNER'S RESPONSIBILITY .....	15
B. EMERGENCY REPAIR .....	16
VI. PRESERVATION, RESTORATION, AND CLEANUP .....	16
A. DISTURBED AREAS .....	16
B. DRAINAGE FACILITIES .....	17
C. CLEANUP .....	17
VII. SPRAYING, CUTTING AND TRIMMING TREES .....	17
A. PERMIT REQUIRED .....	17
B. PROTECTION OF VEGETATION .....	17
C. CHEMICAL BRUSH CONTROL .....	17
D. TREE PRUNING .....	18

## **PART ONE - GENERAL REQUIREMENTS**

### **I. GENERAL PROVISIONS**

#### **A. GENERAL**

1. A permit allowing a Utility Company the privilege of placing its facilities in or on the road right-of-way does not constitute any permanent right of use. Removal, remodeling, maintenance or relocation of the facilities will be promptly accomplished by the owner at no cost to Douglas County.
2. Private Utility Company lines shall not occupy the road right-of-way except where necessary to cross the highway.
3. Utility Companies who utilize subcontractors are responsible for subcontractor compliance with Douglas County specifications, regulations and permits issued pursuant to this Policy. Unsatisfactory work will be rejected and result in permit revocation and may result in denial of future Utility Permits.
4. Subcontractors must carry the required liability insurance unless the subcontractor is covered by the Utility Company insurance.
5. Utility Companies and subcontractors shall follow industry accepted construction and safety practices and follow applicable statutes and regulation(s).
6. The County Engineer or Township Trustee may waive requirements of these standards for road maintenance or safety concerns.
7. An approved and signed copy of the Utility Permit must be on the premises at the start and during the period any work is performed.
8. The Utility Company and its subcontractor(s) are responsible for contacting Dig Safe and for securing additional permits, (i.e. permits for crossing railroad right-of-way, dikes, levees and/or pipeline easement(s)).
9. The Utility Company or its subcontractor(s) must notify the County Engineer and/or Township Trustee when permitted work begins and when the work is completed.
10. The Utility Company will reimburse Douglas County for fees for any consulting services needed in reviewing and approving the application or inspecting the installation, as determined necessary by the County Engineer.

## **B. LIABILITY**

1. Liability insurance shall be provided as more specifically outlined in the Section 9-107-5 of the County Code.
2. The Utility Company or ROW Occupant assumes all risk and liability for accidents and damages that may occur to persons or property from work performed under a Utility Permit or Reimbursable Utility Agreement. The Utility Company or ROW Occupant shall comply with the Underground Utility Damage Prevention Act (K.S.A. 66-1801 et seq.).
3. Douglas County shall not be liable for damage to any utility not installed in the location authorized by any permit or agreement issued pursuant to this UAP.

## **C. CHANGE IN OWNERSHIP**

Douglas County shall be notified in writing of the names and addresses of the new owners within 30 days after a Utility Company changes ownership.

## **D. ABANDON OR RETIRE IN PLACE**

The Utility Company shall notify Douglas County when the utility has been abandoned or retired in place and is responsible for all costs associated with removal (or making safe in place) abandoned or retired in place utility facilities. The Utility Company shall remove all above ground structures, pedestals, markers, manholes, and other structures or installations deemed necessary by the County Engineer or designee.

## **E. RELOCATION FOR ROAD CONSTRUCTION PROJECTS**

Utilities must be relocated within 90 days after notification by Douglas County, or four weeks prior to construction project bid lettings, whichever is later. Utility Companies must contact the County Engineer or designee prior to starting relocation work. Relocation of utilities prior to construction project bid letting may require clearing and grubbing of trees and vegetation. Permission to leave debris for disposal may be granted by the County Engineer or designee. If not feasible as determined by the County Engineer or designee to have all utilities moved prior to a project bid letting, the Utility Company will coordinate with the contractor during the construction of the project. Relocation of utilities during project construction shall not slow progress of the construction. The Utility Company shall be responsible for all costs to Douglas County or a township due to construction project delays for relocation of utilities.

## **F. DISCHARGE OF WASTE MATERIAL**

Applications for a Utility Permit or Reimbursable Utility Agreement for the installation of utility facilities which may discharge materials into the waters of the United States or waters of the State shall comply with all applicable requirements of the Corps of Engineers, Federal, State and local environmental protection agencies with jurisdiction. A copy of any necessary permit or authorization shall be provided to the County Engineer or designee.

## **G. NON-COMPLIANCE**

Non-compliance with any these standards or any permit, license or agreement issued may be

considered as cause for shut down of operations until compliance is assured to the satisfaction of the County Engineer or designee or revocation of the permit at the discretion of the County Engineer or designee. The cost of any work required by Douglas County in the removal of non-complying construction will be assessed against the Utility Company or ROW Occupant.

## **II. PERMITS**

### **A. GENERAL**

1. Utility Permits are required when utility facilities are installed, relocated, removed or maintained along, crossing over or under all highway right-of-way. The Board of County Commissioners has delegated authority to the County Engineer or designee to approve and execute Utility Permits. All such permits are approved by the County Engineer or designee located at the Douglas County Department of Public Works – Engineering Division office.
  - a. A certificate of liability insurance shall be on file with Douglas County for each permit. Signing and all work shall be subject to the requirements of these standards and the Utility Permits.
  - b. Changes in the scope of work on a Utility Permit will require prior review and approval by the County Engineer or designee.
2. Reimbursable Utility Agreements are executed when Utility Company facilities are located on private right-of-way or private easements and must be relocated, adjusted or removed because of highway improvements. Costs for such utility changes are to be reimbursed by Douglas County. Such agreements are prepared and approved by the County Engineer.
  - a. A properly executed Reimbursable Utility Agreement will be considered to be a Utility Permit and all utility facilities relocated or adjusted on highway right-of-way will conform to these standards. Douglas County will prepare a "Utility Permit" for reimbursable utility relocations. These "Utility Permits" are for Douglas County's internal use and Utility Company endorsement is not required.
  - b. Utility relocations accomplished under a highway construction project, where costs are not reimbursable, will require a Utility Permit along with the required liability insurance.

### **B. APPLICATIONS**

Application and plans shall be submitted for review and approval to the County Engineer. The application shall show the location of the utility by route or E911 Road I.D., section, township and range; and position of the utility within the right-of-way noting all construction details such as depths, type of materials, operating pressures, voltages, vertical and horizontal clearances, etc. Plans shall consist of two sets of 8-1/2" x 11" or 11" x 17" sheets; 24" x 36" sheets will only be accepted when smaller sheets would be illegible. Permit applications for pipelines carrying hazardous materials shall display the names of company officials who can be contacted on a 24-hour basis in case of any emergency. The Utility Company shall notify Douglas County of all changes in the calling list

within 7 days of such change.

### **C. Douglas County OFFICE**

Applications for Utility Permits may be obtained at the Douglas County Department of Public Works – Engineering Division office or online.

All applications for utility installations on county or township roads shall be submitted to the Douglas County Department of Public Works – Engineering Division office.

Douglas County Public Works  
3755 E. 25<sup>th</sup> Street  
Lawrence, KS 66046

Douglas County internet address: [www.douglascountyks.org](http://www.douglascountyks.org)

## **III. PROTECTION OF TRAVELING PUBLIC**

### **A. TRAFFIC CONTROL**

1. All utility work on the roadway, within the "Clear Zone", or involving equipment parked in the "Clear Zone" requires a Traffic Control Plan. The required Clear Zone for the particular location shall be determined by the County Engineer or designee. A guide to determining the Clear Zone is located in the Appendix.
2. Traffic Control is to be provided by the Utility Company or ROW Occupant for all Utility Permits whenever such Utility Company work interferes with the movement of traffic or where the work or equipment is located within the Clear Zone.
3. Personnel working on Douglas County right-of-way must wear ANSI Class II High Visibility Safety apparel compliant with 23 CFR Part 634, as set forth in 71 Federal Register 67792 to 67800 (Nov. 24, 2006). The purpose of the regulations is to decrease the likelihood of worker fatalities or injuries caused by motor vehicles and construction vehicles and equipment within the right-of-way.
4. The traveling public shall be warned of the activities of the contractor or individuals involved with utility construction and maintenance within the highway right-of-way by means of signs, flaggers, and traffic control devices as outlined in the latest edition of the "Manual of Uniform Traffic Control Devices" (MUTCD), U.S. Department of Transportation, FHWA.
5. Flaggers will be required according to the MUTCD when utility construction and maintenance work on the roadway (includes pavement) is in progress. Control by flaggers is for the safety of the workers and the traveling public. Flaggers must wear ANSI Class II safety vests at all times when flagging traffic.
6. Typical Signing Plans for traffic control on highways involving "Roadside Work" and "Lane Closure" are included in the Appendix. These are typical plans and should be supplemented if

necessary to conform to the MUTCD.

7. All Traffic Control Plans must be preapproved by the County Engineer or designee.

## **B. STORAGE AND PARKING**

Storage of materials, parking of equipment and vehicles when not used in actual utility work within the highway right-of-way will not be permitted on the right-of-way unless no other alternative is available. If such storage or parking is permitted, then it must be located beyond the Clear Zone and as far to the edge of the right-of-way as possible.

## **IV. DESIGN CONSIDERATIONS**

### **A. DESIGN**

Each Utility Company is responsible for the design of their facilities to be installed within the highway right-of-way or attached to a highway structure.

### **B. MATERIALS**

All Utility Company installations along, crossing over or under highway right-of-way and attachments to highway structures shall be of durable materials designed for long service life expectancy and free from routine servicing and maintenance. Materials shall conform to current applicable material specifications and codes.

### **C. FUTURE EXPANSION**

1. On new installations or adjustments of existing Utility Company lines, provision should be made for known or planned expansion of the Utility Company facilities, particularly those located underground or attached to bridges and structures.
2. Plan future expansion to minimize hazards and interference with highway traffic when additional overhead or underground lines are installed.

## **V. MAINTENANCE AND SERVICING OF UTILITIES**

### **A. UTILITY COMPANY'S RESPONSIBILITY**

1. Maintenance of the utility is the responsibility of the Utility Company.
2. Maintenance must be performed to keep the utility in an as constructed condition and in compliance with the requirements of Federal, State and local statutes, regulations and utility codes.

3. Utility Companies shall replace and stabilize all earth cover and vegetation where the underground utility or its installation has caused erosion.
4. The Utility Company shall repair settlement of backfills, fills, and embankments placed by the Utility Company or its contractors or subcontractor at any tier which may occur within one year of the construction or installation. Any repairs shall be made by the Utility Company within thirty (30) days after receipt of notice from the County Engineer or designee.

## **B. EMERGENCY REPAIR**

1. Emergency repair of utilities located on highway right-of-way is permissible without first obtaining a Utility Permit, if an emergency exists that interrupts critical services and is dangerous to the life, safety or welfare of the public and requires immediate repair. The Utility Company shall take all reasonable safety measures and temporary traffic control measures consistent with the MUTCD to protect the traveling public during repairs and cooperate fully with authorities.
2. The Utility Company will advise the County Engineer or designee of the location as soon as possible but no later than the next business day after discovering the emergency. The County Engineer may require a permit for any completed or ongoing work.

## **VI. PRESERVATION, RESTORATION, AND CLEANUP**

### **A. DISTURBED AREAS**

1. Areas of highway right-of-way disturbed by the installation, maintenance, removal and relocation of utilities shall be kept to a minimum with special care taken to avoid disturbing existing drainage facilities.
2. All excavations will be backfilled within twenty-four (24) hours after work is completed, or as directed by the County Engineer or designee, and all work shall comply with the current edition of the KDOT "Standard Specifications for State Road and Bridge Construction".
3. Disturbed areas shall be returned to normal grade and elevation with adequate compaction of backfill material and all excess or undesirable material removed by the Utility Company. All destroyed vegetation shall be replaced by the Utility Company by sodding or seeding, fertilizing and mulching with seed or sod types and application rates as required by the County Engineer or designee in conformity with methods and allowable seeding dates specified in the KDOT "Standard Specifications for State Road and Bridge Construction." Application rates for various seed types are included in the appendix.
4. Adequate protection against erosion shall be provided by the Utility Company in disturbed areas that are susceptible to erosion. Such protection may be in the form of temporary or permanent seeding, fertilizing, and mulching, rock rip-rap, wash checks, or other material that does not interfere with highway maintenance operations and is approved by the County Engineer or designee.
5. Disturbed or broken survey monuments shall be reestablished by a licensed Land Surveyor.



## **B. DRAINAGE FACILITIES**

Utility Company shall not disturb existing drainage facilities.

## **C. CLEANUP**

Prior to the final inspection for acceptance of work performed on highway right-of-way, the Utility Company shall restore all "Disturbed Areas" as required under Subsection A of this Section, remove all unused material or debris from the work area, and leave the right-of-way in a clean, acceptable condition.

## **VII. SPRAYING, CUTTING AND TRIMMING TREES**

### **A. PERMIT REQUIRED**

Trees, shrubs, bushes, vines or ground cover on the highway right-of-way shall not be sprayed, trimmed, cut down, rooted up, removed, or mutilated in any manner, unless a Utility Permit is granted.

### **B. PROTECTION OF VEGETATION**

Consistent with the preservation of planted vegetation, consideration will be given to Utility Company for the necessary trimming, clearing or removal of vegetation to provide adequate clearance of overhead wires. Such work will be done in accordance with established practices and standards, such as those outlined in the KDOT "Highway Maintenance Manual". Approval shall not be granted for wasteful or wanton trimming or removal .

### **C. CHEMICAL BRUSH CONTROL**

Spraying brush and seedling tree growth by Utility Companies or ROW Occupant is prohibited unless a permit is granted by the County Engineer or designee. Such activities shall be performed with extreme caution. The Utility Company or ROW Occupant shall be responsible for the performance of their employees, agents, contractors or subcontractors at any tier in the application of chemicals for brush control.

1. All spraying shall be done by a licensed herbicide applicator, licensed under Category Six of K.S.A. 2-2444a and approved by the Kansas Department of Agriculture.
2. Liability insurance, including coverage for chemical application damage, shall be provided in accordance with the County Code prior to issuing a Utility Permit for the use of chemicals.
3. Work involved on each permit application must be reviewed in detail and approved in writing by the County Engineer or designee prior to issuing the permit.
4. The name and type of chemical weed and brush killers that will be used on or near road right-of-

way shall be listed on the permit application.

5. Plants over five feet in height shall not be sprayed. Remove brush over five feet in height. Stumps shall be cut flush or below ground level and treated to prevent regrowth.
6. Shrubbery-type growth such as dogwood, sumac, redbud, plum, etc., shall not be sprayed unless prior approval is received in writing from the County Engineer or designee.
7. Steep slopes where brushy growth is a major factor in preventing erosion shall not be sprayed without prior written approval of the County Engineer or designee.
8. The spraying program shall be arranged, if possible, so that long stretches of right-of-way or both sides of the road are not treated at the same time.

#### **D. TREE PRUNING**

Tree pruning on highway right-of-way for utility lines will utilize best horticulture practices.

1. The pruning, trimming or removal of trees for utility line clearance or other purposes requires a Utility Permit from the County Engineer or designee or Township Trustee.
2. Any and all limbs trimmed shall be removed with a clean cut.
3. All cut branches, dead limbs, etc., shall be removed from Clear Zone while traffic control is in place and cleared from the highway right-of-way within forty-eight (48) hours or as directed by the County Engineer or designee. Such materials shall not be burned along the roadside unless such permission is granted on the permit and all required permits for open burning have been obtained by the Utility Company or ROW Occupant.
4. The Utility Company or ROW Occupant shall be held liable for any damage to grass, crops, native shrubs or trees arising from open burning of brush.
5. The Utility Company or ROW Occupant shall secure all required permits for open burning.

# **PART TWO**

## **UTILITIES ON PERMITTED ROADS**

**PART TWO  
UTILITIES ON PERMITTED ROADS**

	PAGE
I. GENERAL PROVISIONS .....	21
A. LOCATION .....	21
B. TRENCHING AND BACKFILL .....	21
C. PIPELINE INSTALLATIONS .....	22
II. ABOVEGROUND INSTALLATIONS .....	23
A. GENERAL .....	23
III. UNDERGROUND INSTALLATIONS .....	24
A. GENERAL .....	24
B. UNDERGROUND INSTALLATIONS CROSSING THE ROW .....	25
IV. ENCASEMENT OF UTILITIES .....	26
A. GENERAL .....	26
B. CASING REQUIREMENTS FOR UTILITIES CROSSING ROW .....	27
C. BORING .....	28
D. CASING MATERIAL .....	29

## **PART TWO - UTILITIES ON PERMITTED ROADS**

### **I. GENERAL PROVISIONS**

This Part of the Policy applies to all public and private utilities, including electric power, telephone, telegraph, cable television, water, gas, oil, petroleum products, steam, chemicals, sewage, drainage, irrigation, and similar lines that are to be located, adjusted, or relocated, within the right-of-way under the jurisdiction of the County Engineer. Such utilities may involve underground, surface, or aboveground facilities, either singly or in combination.

Part One -"General Requirements" and Part THREE -"Attachments to Bridges and Structures" contain general information and other requirements which pertain to Part Two and are to be referred to in application of these standards.

Utility Company lines constructed on public road right-of-way shall be in conformance with the current "National Electrical Safety Code", "American Waterworks Association Specifications", "Federal Pipeline Safety Regulations" and KDOT "Standard Specifications for State Road and Bridge Construction". Utilities must be located beyond the clear zone unless otherwise approved by the County Engineer or designee.

#### **A. LOCATION**

1. Utility Company installations shall be located to minimize need for later adjustment to accommodate future road improvements and to permit servicing such lines with minimum interference to road traffic and road maintenance operations.
2. All Utility Company installations, adjustments, and/or relocations, shall be located with consideration to road and Utility Company costs, impacts on road users, interference with road facilities and their operation, and impacts on road maintenance operations.
3. Parallel installations shall be located on uniform alignment within ten feet or less of the right-of-way line to reduce impacts on traffic operations and preserve space for future road improvements or other transportation purposes.
4. Utility Company line crossings of road right-of-way are to be installed perpendicular to the road alignment to the extent possible.
5. The horizontal and vertical location of Utility Company lines within the road right-of-way shall conform to the dimensions outlined in Sections II and III of this Part.
6. Attachments to bridges and structures must be in accordance with this Policy outlined in Part THREE -"Attachments to Bridges and Other Structures ".

#### **B. TRENCHING AND BACKFILL**

1. Where soil and depth conditions permit, trenches should be cut to have vertical faces with a

maximum width of outside diameter of pipe plus two feet. Trenches must be shored where necessary for safety and to protect the traveled way, shoulders and slopes.

- a. Bedding shall be provided to a depth of six inches or half of the diameter of the pipe, whichever is less. This requirement may be waived for lines with inside diameter of two inches or less, and installed in compliance with the American Waterworks Association (AWWA) standards, or other applicable Industry Standards.
  - b. Bedding material shall be free of lumps, clods, stones, and frozen material and shall be graded to a firm but yielding surface without abrupt changes in bearing value.
2. Backfilling of open trenches shall use only approved materials that will produce a dense, well-compacted backfill. Materials containing frozen soil, sod, debris, or organic material shall not be used.
- a. The materials shall be placed in uniform layers not to exceed eight inches in depth and compacted by means of suitable equipment or by tamping with mechanical or hand tampers.
  - b. The moisture content of the soil used for backfilling shall be uniform and shall be such that required densities can be obtained.
3. A blasting plan shall be submitted to the County Engineer or designee before blasting a trench for utilities in rock on the right-of-way. A blasting plan will also be reviewed before blasting a trench for utilities in rock on the right-of-way within 100 feet (30.5 meters) of a bridge or road structure.

## **C. PIPELINE INSTALLATIONS**

1. Utility Companies shall specify the type and class of material, test, design and maximum working pressures of their pipeline installations. Utility Companies operating pipelines that are not constructed, operated, and maintained under regulations established by the U.S. Department of Transportation shall upon revision in the class of material or an increase in the maximum operating pressure, notify the County Engineer in writing of such revisions.
2. Vents are appurtenances by which fluids between carrier and casing may be inspected, sampled, exhausted, or evacuated.
  - a. Vents shall be located at the high end of short casings and at both ends of casing longer than 150 feet (45 meters).
  - b. Vent standpipes shall be located and constructed so as not to interfere with maintenance of the road or be concealed by vegetation. Where possible, they shall be marked and located at the right-of-way line. The markers shall display the name and telephone number of company officials to contact in case of emergency.
3. Drains are appurtenances by which liquids or heavy gases may be evacuated or exhausted.

Roadside ditches or natural water courses shall not be used for purging the carrier unless

specifically authorized by the County Engineer and any state or federal agency with jurisdiction over said ditches or water courses.

4. The Utility Company shall place readily identifiable and suitable markers at the right-of-way where it crosses the road except in those cases where a vent serves as a marker.

## II. ABOVEGROUND INSTALLATIONS

### A. GENERAL

1. Aboveground Utility Company installations in rural areas should be located at the outer limits of the right-of-way, preferably within three feet or less of the right-of-way line. As right-of-way widths allow, when considering specific installations, facilities shall not be allowed closer to the traveled way than the Clear Zone, as determined by the County Engineer. A general guide to the Clear Zone distance is provided in the Appendix. This table is adopted from the AASHTO publication, "Roadside Design Guide" current addition.

Poles, guys, anchors, or other appurtenances shall not be located in the traveled way, shoulder slopes, ditches, at drainage structure openings, or on roadway shoulders. Exceptions may be permitted with the approval of the County Engineer or designee, but generally facilities should not be allowed closer to the traveled way than the Clear Zone. All poles, guys, anchors, or other appurtenances shall be located to minimize interference with maintenance operations of Douglas County.

2. Service lines (those that run from the primary lines on Douglas County right-of-way to a house or business) should utilize a "Slack" line configuration. The "Slack" line configuration will eliminate the need for additional guy anchors extending on to the right-of-way and congesting the utility corridor.
3. The minimum vertical clearance to overhead installations including guy wires and telephone poles should be that required by the National Electrical Safety Code, Institute of Electrical and Electronics Engineers, Inc. However, additional clearance may be required by Douglas County in certain instances.

General clearance guides are provided as follows:

<u>Vertical Clearance</u>	<u>Line Voltage</u>
18 feet	Any Communication Line
18 feet	0-750
20 feet	750-22,000
**	22,000-470,000
***	Over 50,000

\*\* Increase general clearance 0.4 inch for each 1,000 volts of the excess over 22,000 volts.

\*\*\* All clearances for lines over 50,000 volts shall be based on maximum operating voltage. For voltages exceeding 50,000 volts, the additional clearance specified shall be increased 3% for each 1,000 feet in excess

of 3,300 feet above mean sea level.

4. The maximum height of any public utility facility shall be 65 feet.
5. Measured parallel to the road and at the ground surface, the combined width of all of the above ground facilities owned by one public utility shall not exceed five feet within any fifty foot length of road.
6. Measured perpendicular to the road and at the ground surface, the maximum width of any above ground facility shall not exceed three feet.
7. Installations should be limited to single pole type construction with vertical configuration of conductors and cables. Joint-use single pole construction is encouraged at locations where more than one utility or type of facility is involved.

### **III. UNDERGROUND INSTALLATIONS**

#### **A. GENERAL**

1. Underground utility installations should be located within the ten feet utility corridor at the right-of-way line, unless otherwise approved by the County Engineer or Township Trustee. All installations and appurtenances shall be located to minimize interference with maintenance operations of Douglas County and other utilities in the corridor.  
All Utility Company appurtenances above the ground surface shall be located outside the Clear Zone in the ten feet utility corridor at the right-of-way line.
2. Unless otherwise approved by the County Engineer or Township Trustee, utilities will not be permitted in the traveled way, median shoulder, shoulder slope, or ditch unless crossing perpendicular to the traveled way. Exception will be considered in extreme cases and require written approval by the County Engineer or designee.
3. Measured perpendicular to the road, the combined width of all of the underground facilities owned by one public utility shall not exceed five feet, except where necessary to cross the road.
4. Underground facilities shall be installed at a minimum depth of four feet below ditch or culvert flowline elevation and thirty inches below existing grade of ground surface outside of ditch back slopes. Such cable may require greater burial depth at certain locations including, but not limited to, crossings of streambeds, side roads, and major entrances. In no case shall the depth of cover for any underground facilities be less than that meeting applicable Industry Safety Guidelines.
  - a. If less than minimum depth is necessary because of existing utilities, water table, ordinance, or similar reasons the line shall be rerouted or protected with a casing, suitable bridging, concrete slab or other appropriate means.
  - b. Locations where it will be difficult to attain minimum depth due to wet or rocky terrain shall be avoided. Any plan location change must be approved by the



County Engineer or designee.

5. Manholes shall not be located in a bridge deck, traveled way, median, shoulder, shoulder slope, or ditch, and shall not protrude above the surrounding ground.
6. If directed by the County Engineer or designee, or the Township Trustee, any above ground structures (i.e. pedestal) shall be marked by a four foot tall post. All pedestal type structures shall be located at the outer limits of the right-of-way, preferably within two feet or less of the right-of-way line.
7. Buried electrical lines paralleling the right-of-way will only be allowed where Douglas County determines there is no reasonable alternative.
  - a. The electrical line shall be buried a minimum depth of 48 inches unless it is encased.
  - b. A tape shall be placed 12 inches below grade to mark the location of the cable.
  - c. Whenever the electrical line crosses a roadway, it shall be cased; this includes all side roads.
  - d. Electrical lines crossing county roads shall be marked with an aboveground marker on each side of the right-of-way.
  - e. The Utility Company shall mark buried cable with above ground markers a minimum of four times per mile. These markers may be placed directly above the buried cable, or offset at the right-of-way line at the discretion of the County Engineer or designee.
  - f. Douglas County may also require the encasement of the electrical line whenever it is in close proximity of a traffic control sign for the safety of Douglas County personnel when replacing downed signs.
8. Utility Company lines installed parallel to road right-of-way require casing at certain locations. Such locations include, but are not limited to, crossings of side roads and major entrances.
9. All buried plastic pipes shall be required to have a trace wire for ease of locating.
10. Private and public Utility Company lines shall not be permitted to be routed through drainage structures. Attachment to drainage structures may be permitted (see Part Three, Attachment to Bridges and Other Structures).
11. Fiber optic lines shall be buried at a depth of 42 inches and have a trace wire for ease of locating.
12. Buried vaults larger than a hand hole (3 foot x 4 foot) shall be located on private easement. Aboveground equipment cabinets other than splitter posts shall be located on private easement.

## **B. UNDERGROUND INSTALLATIONS CROSSING RIGHT-OF-WAY**

1. All utilities crossing under ditches and roadways should have a minimum depth of cover of four feet below ditch grade (original plan grade elevation). In fill sections, the natural ground line at the toe of the slope will be considered as ditch grade. However, in no case shall the depth of cover be less than that meeting applicable Industry Safety Guidelines.
  - a. If the minimum depth is not possible because of existing utilities, water table, ordinances, or similar reasons, the line shall be rerouted or protected with a casing, suitable bridging, concrete slab or other appropriate means.
  - b. Locations that are considered unsuitable or undesirable shall be avoided. These include, but are not limited to, locations as in deep cuts, near bridge footings, and in wet or rocky terrain where it is difficult to obtain minimum depth. Plan location changes must be approved by the County Engineer or designee.
2. Underground installations may be made by open trenching from the right-of-way line to the toe of the fill slope in fill sections and to the toe of the shoulder slope in cut sections. No trenching or excavating shall be allowed in the fill or shoulder slope unless approved by the County Engineer or designee. The remainder will be tunneled, augured, or dry bored through the roadway and shall be cased, unless casing is waived by the County Engineer or designee.

## **IV. ENCASEMENT OF UTILITIES**

### **A. GENERAL**

1. Casings are oversized load bearing conduits or ducts through which a utility is inserted:
  - a. To protect the roadway from damages and to provide for repair, removal and replacement of the utility without interference to road traffic.
  - b. To protect the carrier pipe from external loads or shock, either during or after construction of the road.
  - c. To convey leaking fluids or gases away from the area directly beneath the traveled way to a point of venting at or near the right-of-way line.
2. The casing shall include necessary appurtenances, such as vents, drains, and markers. Casing pipe shall be sealed at both ends with a suitable material to prevent water or debris from entering the annular space between the casing and the carrier, in accordance with Pipeline Industry Standards.
3. Utility Company lines crossing road right-of-way shall be cased from top of ditch back slope to top of ditch back slope. The County Engineer or designee may allow minimum encasing from toe of back slope to toe of back slope in ditch sections and from toe of fill slope to toe of fill slope in fill sections.
4. Utility Company lines installed parallel to road right-of-way require casing at certain locations.

Locations included, but not limited to, are the crossings of side roads and major entrances.

## **B. CASING REQUIREMENTS FOR UTILITIES CROSSING THE RIGHT-OF-WAY**

1. Underground electric service lines shall be placed in conduit or ducts from right-of-way line to right-of-way line and shall be clearly marked by the Utility Company at the outer limits of the right-of-way.
2. Underground fiber optic lines shall be placed in schedule 40 PVC, HDPE, or equivalent from right-of-way to right-of-way line, with a tracer wire and must be clearly marked by the Utility Company at the limits of the right-of-way.
3. Direct buried telephone and communications cable will not be required to be cased.
4. Lines carrying high-pressure natural gas, liquid petroleum products, ammonia, chlorine, or other hazardous or corrosive products need not be cased provided they are:
  - a. Welded steel pipelines;
  - b. Cathodically protected, if welded steel;
  - c. Coated in accordance with accepted Industry Standards, if welded steel;
  - d. Wall thickness is thick enough to meet requirements of the Federal Pipeline Safety Regulations -Code of Federal Regulations -Title 49 Code of Federal Regulations Parts 191 and 192 (Natural Gas) or Part 195 (Liquid Petroleum Gas) with respect to wall thickness;
  - e. Designed for operating stress levels in accordance with Federal Pipeline Safety Regulations;
  - f. Natural gas distribution and service lines with maximum pressure of sixty pounds per square inch (PSIG), are of copper, steel or plastic composition, and have an inside diameter of two inches (50 millimeters) or less.

When a waiver of casing is requested, the Utility Company shall provide, as a part of the Permit, a statement of certification that Utility Company pipeline will comply with the applicable conditions and provisions contained in items (a) through (f) above.

5. Gas pipelines not meeting applicable conditions and provisions (a) through (f) above shall be cased within the right-of-way limits and shall be vented and marked at the outer right-of-way limits. The markers shall give the name of the owner and phone number to contact in case of an emergency.
6. Sanitary sewer lines crossing the right-of-way must be encased from right-of-way line to right-of-way line. An exception shall be made for gravity flow lines placed prior to road construction, properly bedded, and constructed of heavy duty cast or ductile iron pipe with suitable

mechanical and/or restraint joints and seals. Suitability shall be determined by the County Engineer or designee in writing.

7. Water lines must be cased, from top to top of back slope in ditch sections or toe to toe of fill slope in fill sections. Venting and sealing of casement is not required. Casement is not required provided:
  - a. Water line is placed prior to road construction utilizing extra strength cast iron or ductile iron with mechanical and/or restraint joints and seals, and is properly bedded. The extra strength pipe is to be used from right-of-way line to right-of-way line.
  - b. Any copper, steel, or plastic waterline has an inside diameter of two inches or less.
8. All plastic pipe with inside diameter greater than two inches must be cased from top to top of ditch back slopes and meet minimum ASTM specifications and all applicable laws and codes. In certain instances as determined appropriate by Douglas County, minimum casing may be allowed requiring encasing from toe of back slope to toe of back slope in ditch sections and from toe of fill slope to toe of fill slope in fill sections.
9. Uncased Utility Company installations, which by reason of shallow depth or location make them vulnerable to damage from road construction or maintenance operations, shall be protected with suitable bridging, concrete slabs or other appropriate measures.
10. Underground utility installations not listed above may be installed without protective casing, where it is acceptable to both the Utility Company and Douglas County. Any such determination by Douglas County shall be in writing. Approval will be determined by the County Engineer or designee on an individual basis and limited to:
  - a. Open trenched construction;
  - b. Small bores;
  - c. Pipelines that are continuous (seamless) without joints;
  - d. Gas lines designed using the National Gas Institute Guidelines for Pipelines Crossing Railroads and Highway. Evidence must be submitted showing that the crossing is designed without encasement to meet stresses at the road crossing.

## **C. BORING**

1. Underground utilities crossing hard surfaced roads must be bored or jacked. No open trenching across hard surfaced roads will be permitted.
2. Pits for boring, tunneling or jacking will not be permitted closer to the roadway than toe of fill in fill sections or toe of shoulder slope in ditch sections when allowed on the right-of-way.

3. Casing and pipeline installations shall be accomplished by dry boring, tunneling, jacking, trenching, or other approved methods.
  - a. The use of water under pressure (jetting) or puddling will not be permitted to facilitate boring, pushing, or jacking operations. Some boring may require water to lubricate cutter and pipe and under such conditions, may be considered dry boring, with prior approval from the County Engineer or designee.
  - b. Where unstable soil conditions exist, boring or tunneling operations shall be conducted in such a manner as not to be detrimental to the roadside being crossed.
  - c. If excessive voids or a too large bored hole is produced during casing or pipeline installations, or if it is necessary to abandon a bored or tunneled hole, prompt remedial action shall be taken by the Utility Company, subject to the written approval of the County Engineer or designee.
  - d. All voids or abandoned holes caused by boring or jacking are to be filled by pressure grouting when deemed necessary by the County Engineer or designee in writing. The grout material should be a sand cement slurry with a minimum of two sacks of cement per cubic yard and a minimum of water to assure satisfactory placement.
4. The hole diameter resulting from bored or tunneled installations shall not exceed the outside diameter of the utility pipe, cable or casing (including coating) by more than 1.5 inches on pipes with an inside diameter of 12 inches or less; or two inches on pipes with an inside diameter greater than 12 inches .

#### **D. CASING MATERIAL**

The following materials are acceptable for use in the casing of utility facilities when permitted by industry requirements and standards.

1. Welded steel pipe, smooth wall, in sound condition meeting the requirements of the current KDOT "Standard Specifications for State Road and Bridge Construction".
2. Corrugated metal pipe and coupling band meeting the requirements of the current KDOT "Standard Specifications for State Road and Bridge Construction".
3. Reinforced concrete pipe meeting the requirements of the current KDOT "Standard Specifications for State Road and Bridge Construction".
4. Vitrified clay pipe meeting the requirements of the current KDOT "Standard Specifications for State Road and Bridge Construction".
5. Cast iron pipe or ductile iron of the same class as used for carrier pipe, providing it meets the minimum ASTM Specifications. A statement certifying that such specifications are met will be submitted as a part of the permit.

6. Polyvinyl Chloride (PVC) meeting the requirements of the current KDOT "Standard Specifications for State Road and Bridge Construction."

High-Density Polyethylene (HDPE) providing it meets the minimum ASTM Specifications.

Chlorinated Polyvinyl Chloride (CPVC) providing it meets the minimum ASTM Specifications and all applicable laws and codes, in accordance with the listing below:

CPVC -WATER LINE PIPE  
ASTM SPECIFICATION  
F 441

<u>Casing Diameter</u>	<u>Min. Wall Thickness</u>	<u>Schedule</u>
4 inches (100 mm)	0.237 inches (6.02 mm)	40
6 inches (150 mm)	0.280 inches (7.11 mm)	40
8 inches (200 mm)	0.322 inches (8.18 mm)	40
10 inches (250 mm)	0.365 inches (9.27 mm)	40
12 inches (300 mm)	0.460 inches (10.31 mm)	40

The use of PVC pipe for casing is acceptable up to a maximum diameter of 12 inches (300 millimeters).

7. Electric conduits may be of non-metallic materials such as polyvinyl chloride, high-density polyethylene, or vitrified clay.

# **PART THREE**

## **ATTACHMENTS TO BRIDGES AND OTHER STRUCTURES**

**PART THREE  
ATTACHMENTS TO BRIDGES  
AND  
OTHER STRUCTURES**

	PAGE
I. GENERAL PROVISIONS.....	33
A. UTILITY PERMIT.....	33
B. HAZARDOUS MATERIALS.....	33
II. PERMITTED ROADS.....	34
A. DESIGN.....	34
B. LOCATION AND METHOD OF ATTACHMENT.....	34
C. EXCAVATIONS.....	35
D. MATERIALS.....	35
E. MAINTENANCE.....	35
F. PIPELINES.....	35
G. COMMUNICATIONS AND ELECTRIC LINES.....	36



**PART THREE**  
**ATTACHMENTS TO BRIDGES**  
**AND**  
**OTHER STRUCTURES**

**I. GENERAL PROVISIONS**

**A. UTILITY PERMIT**

1. Applications for all Utility Company attachments to bridges and structures shall be authorized by a Utility Permit.
2. Structure insurance coverage, for damages that may occur by reason of pipeline attachments carrying PETROLEUM, HAZARDOUS, AND/OR CORROSIVE PRODUCTS, shall be provided by the Utility Company in an amount determined by the County Engineer or designee for each bridge, structure or retaining wall system. The amount of insurance shall at a minimum meet or exceed the replacement cost of the structure as determined by the County Engineer or designee. The amount of insurance may be reviewed annually and adjusted with the current cost of replacement of the structure.
3. A permit allowing a Utility Company the privilege of attaching its facilities to a bridge or road structure does not constitute any permanent right for such attachment or placement. Any removal, remodeling, maintenance, or relocation of the attachment or installation, will be promptly accomplished by the Utility Company at no cost to Douglas County.
4. Provisions for a Utility Company attachment may be included during the design of a structure. See Section II.A, 2 for more information.
5. Utilities, when permitted, are to be installed, serviced, or maintained without access from the bridge deck or without interfering with any retaining wall system backfill.
6. The County Engineer or designee shall review and approve the Utility Company's proposal, particularly the measures to be taken to preserve the structure, the road, and their safe operation, maintenance and appearance.

**B. HAZARDOUS MATERIALS**

Permit applications for pipelines carrying hazardous materials shall contain emergency contact phone numbers available on a twenty-four hour basis, in case of emergency. The Utility Company shall notify the County Engineer or designee in writing of any changes in the calling list within seven (7) days of any change.

## **II. PERMITTED ROADS**

### **A. DESIGN**

1. The Utility Company is responsible for the design of their facility's attachment to a bridge or road structure shall submit plans for review and approval. Attachment plans will include catalog cuts of attaching hardware and construction plans detailing the method of attaching the utility and position of the utility on any bridge or structure.
2. When a new structure is in the design stage, the Utility Company, through cooperation with the County Engineer or designee, may arrange for conduit and pipeline support systems to be included in the bridge construction plans. The additional cost of extra structural steel and fabrication needed to support the pipeline and/or conduit beyond what is needed for road purposes will be determined, and this cost will be invoiced to the Utility Company by the County Engineer at the time of design. This amount will be submitted along with the Utility Permit, which will include final design details outlining this attachment. The conduit itself for bridge attachment is to be supplied and installed later by the Utility Company. No Permit will be issued until all costs assessed to the Utility Company are paid in full.
3. Transition of alignment of utility from paralleling right-of-way to bridge or structure should be perpendicular to the roadway.
4. Satisfactory provisions for longitudinal conduit or pipeline movement due to temperature differentials or lineal expansion and contraction of the bridge shall be made in conduit or pipeline designs. Such provisions may be line bends, flexible couplings, or other methods acceptable under appropriate Industry Codes and Practices.
5. Utility Company lines will not be permitted through bridge abutments.
6. Manholes used to service the utility shall not be located in the bridge deck. Manholes shall be located beyond the edge of the wearing surface of the bridge or structure and outside of the roadway (pavement and shoulders).

### **B. LOCATION AND METHOD OF ATTACHMENT**

1. The County Engineer or designee may be contacted for recommended locations and acceptable types of attachments for various bridges. Although road structure types and site conditions vary, some general standards have been adopted. The KDOT Utility Attachment Placement drawings are available in the Appendix as an aide in determining acceptable bridge attachments.
2. Whenever possible, attachments will be placed on the downstream side of bridges. Generally, Utility Company pipelines and conduits will be attached to diaphragms located between girders.
3. Prohibited:

- a. Anchors driven using the explosive type driving force method.
- b. All welding and drilling on steel members.
- c. All drilling in pre-stressed and reinforced concrete girders.
- d. Attachment of conduits to bridge handrail and/or guardrail components.
- e. Pipelines using bridge members to resist forces generated by fluids in motion.

## **C. EXCAVATIONS**

Any open trench or excavation required in conjunction with bridge or structure attachments will be backfilled within twenty-four hours after work is completed, in accordance with KDOT "Standard Specifications for State Road and Bridge Construction", or as directed by the County Engineer or designee.

## **D. MATERIALS**

1. All attachments to bridges and structures shall be of durable materials designed for long service life expectancy and free from routine servicing and maintenance. Conformance with current applicable materials specifications and codes is mandatory.
2. All steel materials used in attaching a utility to a structure must be stainless or galvanized.

## **E. MAINTENANCE**

1. Maintenance of the Utility Company facility is the responsibility of the Utility Company.
2. The installations shall be maintained to the satisfaction of the County Engineer or designee.
3. Maintenance of the utility attachments to bridges will not be performed from the bridge deck.

## **F. PIPELINES**

1. Pipelines carrying liquid petroleum, hazardous, or corrosive products will not be permitted to be attached to bridges or structures except in extreme cases where the Utility Company can document that any other location is extremely difficult and of unreasonable cost to the Utility Company and to the consumer and the County Engineer or designee approves the attachment or placement in writing.
2. Pipelines carrying natural gas, liquid petroleum products, or other volatile fluid or gas under pressure will require installation of emergency shut off valves. Valves shall be placed on each side of the bridge.
3. Pipelines shall be encased:

Attachment to Bridges: the length of the bridge with the casing carried beyond the back of the bridge abutments and opened or vented at each end to detect leakage, when the line carries fluids such as:

- i. petroleum, hazardous and/or corrosive products, sewage etc., or
- ii. waterlines carried over railroads, or other roads.

4. Carrier and casing pipe shall be suitably insulated from electric power line attachments.

## **G. COMMUNICATIONS AND ELECTRIC LINES**

1. Attachment to Bridges

Communication and electric power line attachments shall be suitably insulated, grounded and carried in protective conduit or pipe from point of exit from the ground to re-entry.

# APPENDIX

# APPENDIX

	PAGE
REFERENCES .....	39
CLEAR ZONE .....	40
KANSAS UNDERGROUND UTILITY DAMAGE PREVENTION ACT.....	41
STANDARD BRIDGE ATTACHMENTS	
Steel Bridge	
Bent Plat Diaphragms -Single or Multiple Conduit.....	42
Cross Frame Diaphragms -Single or Multiple Conduit.....	43
Concrete Beam Bridges – Single or Multiple Conduit .....	46
Reinforced Concrete Slab Bridge.....	47
Hanger and Clamp Types .....	48
TRAFFIC CONTROL TYPICAL APPLICATIONS	
TA-1.....	49
TA-6.....	50
TA-10.....	51
TA Meaning of Symbols.....	52
INDEX.....	53

## REFERENCES

1. "KDOT Utility Accommodation Policy", 2007, Kansas Department of Transportation
2. "Guide for Accommodating Utilities within Right-of-Way for Counties & Small Cities", March 2007, Kansas Local Technical Assistance Program (LTAP) and Kansas University Transportation Center
3. Manual on Uniform Traffic Control Devices, 2009 Edition, U.S. Department of Transportation, Federal Highway Administration
4. "AASHTO Roadside Design Guide", Current Edition, American Association of State Highway and Transportation official publication
5. Highway Maintenance Manual, Bureau of Construction and Maintenance, Kansas Department of Transportation
6. Standard Specifications for State Road and Bridge Construction, Current Edition, Kansas Department of Transportation

# CLEAR ZONE

Clear Zone Distances (In feet from the edge of the through traveled way)

[U.S. Customary Units]

DESIGN SPEED	DESIGN ADT	FORESLOPES			BACKSLOPES		
		1V:6H or flatter	1V:5H TO 1V:4H	1V:3H	1V:3H	1V:5H TO 1V:4H	1V:6H or flatter
40 mph or less	UNDER 750	7 - 10	7 - 10	**	7 - 10	7 - 10	7 - 10
	750 - 1500	10 - 12	12 - 14	**	10 - 12	10 - 12	10 - 12
	1500 - 6000	12 - 14	14 - 16	**	12 - 14	12 - 14	12 - 14
	OVER 6000	14 - 16	16 - 18	**	14 - 16	14 - 16	14 - 16
45-50 mph	UNDER 750	10 - 12	12 - 14	**	8 - 10	8 - 10	10 - 12
	750 - 1500	14 - 16	16 - 20	**	10 - 12	12 - 14	14 - 16
	1500 - 6000	16 - 18	20 - 26	**	12 - 14	14 - 16	16 - 18
	OVER 6000	20 - 22	24 - 28	**	14 - 16	18 - 20	20 - 22
55 mph	UNDER 750	12 - 14	14 - 18	**	8 - 10	10 - 12	10 - 12
	750 - 1500	16 - 18	20 - 24	**	10 - 12	14 - 16	16 - 18
	1500 - 6000	20 - 22	24 - 30	**	14 - 16	16 - 18	20 - 22
	OVER 6000	22 - 24	26 - 32 *	**	16 - 18	20 - 22	22 - 24
60 mph	UNDER 750	16 - 18	20 - 24	**	10 - 12	12 - 14	14 - 16
	750 - 1500	20 - 24	26 - 32 *	**	12 - 14	16 - 18	20 - 22
	1500 - 6000	26 - 30	32 - 40 *	**	14 - 18	18 - 22	24 - 26
	OVER 6000	30 - 32 *	36 - 44 *	**	20 - 22	24 - 26	26 - 28
65-70 mph	UNDER 750	18 - 20	20 - 26	**	10 - 12	14 - 16	14 - 16
	750 - 1500	24 - 26	28 - 36 *	**	12 - 16	18 - 20	20 - 22
	1500 - 6000	28 - 32 *	34 - 42 *	**	16 - 20	22 - 24	26 - 28
	OVER 6000	30 - 34 *	38 - 46 *	**	22 - 24	26 - 30	28 - 30

\* Where a site specific investigation indicates a high probability of continuing crashes, or such occurrences are indicated by crash history, the designer may provide clear-zone distances greater than the clear-zone shown in Table 3.1. Clear zones may be limited to 30 ft for practicality and to provide a consistent roadway template if previous experience with similar projects or designs indicates satisfactory performance.

\*\* Since recovery is less likely on the unshielded, traversable 1V:3H slopes, fixed objects should not be present in the vicinity of the toe of these slopes. Recovery of high-speed vehicles that encroach beyond the edge of the shoulder may be expected to occur beyond the toe of slope. Determination of the width of the recovery area at the toe of slope should take into consideration right-of-way availability, environmental concerns, economic factors, safety needs, and crash histories. Also, the distance between the edge of the through traveled lane and the beginning of the 1V:3H slope should influence the recovery area provided at the toe of slope. While the application may be limited by several factors, the foreslope parameters which may enter into determining a maximum desirable recovery area are illustrated in Figure 3.2.

Source: Roadside Design Guide



**KANSAS UNDERGROUND UTILITY DAMAGE PREVENTION  
ACT  
K.S.A. 66-1801 (DIG SAFE)**

1-800-334-7233 (Dig Safe)

Color Coding for Locating Utility Company Lines

RED	Electric Power Lines, Cables, Conduit and Lighting Cables
YELLOW	Gas, Oil, Steam, Petroleum, or Gaseous Materials
ORANGE	Communication, Alarm or Signal Lines, Cables or Conduit including Cable TV
BLUE	Water, Irrigation and Slurry Lines
GREEN	Storm Drain Lines/Sewer
PINK	Survey Markings
WHITE	Proposed Excavation

Tolerance Zone: The area within 24 inches (600 millimeters) of the outside dimensions in all horizontal directions of an underground facility.

# KANSAS DEPARTMENT OF TRANSPORTATION

## UTILITY ATTACHMENT PLACEMENT

For a Steel Superstructure Bridge with bent plate diaphragms

Support Spacing  
\_\_\_\_\_ meters  
( \_\_\_\_\_ )feet

Diameter Conduit(s)  
\_\_\_\_\_ mm  
( \_\_\_\_\_ )inches

Weight (Includes Conduit,  
Support System and Cables)  
\_\_\_\_\_ kg/ m  
( \_\_\_\_\_ )lbs/ ft.

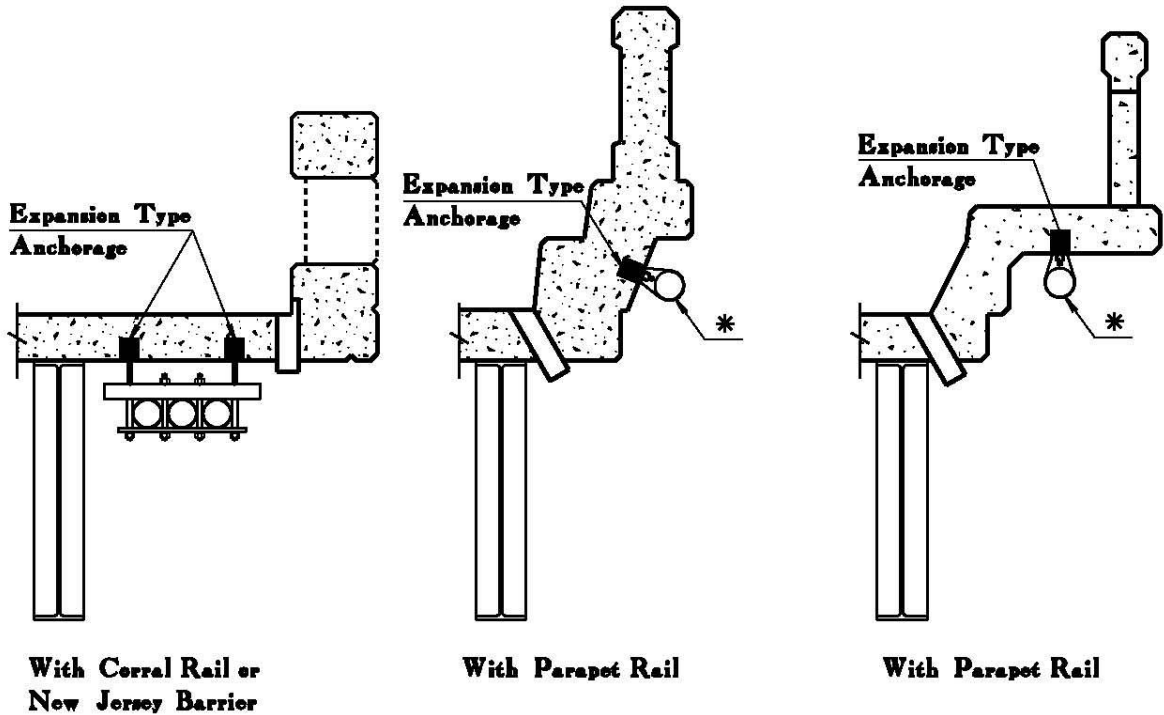

### SINGLE OR MULTIPLE CONDUITS - ALTERNATE LOCATIONS -

\* Drilling, welding, or cutting of any structural steel is not allowed.  
Use Conduit or Beam Clamps in place of drilling or cutting.

**NOTE: All steel materials used in attaching a utility to a structure must be stainless or galvanized.**

Plot Date : 5/9/2007

View= Plot1

Plotted By : ronalds

Plot File : WABridge Inspection\B-School\Bridges Insp. Kansas\Utility Attachments\ultra.mon.dgn

# KANSAS DEPARTMENT OF TRANSPORTATION

## UTILITY ATTACHMENT PLACEMENT

For a Steel Superstructure Bridge with bent plate diaphragms

<b>Support Spacing</b> _____ meters ( _____ )feet	<b>Diameter Conduit(s)</b> _____ mm ( _____ )inches	<b>Weight (Includes Conduit, Support System and Cables)</b> _____ kg/ m ( _____ )lbs/ ft.
---	---	---

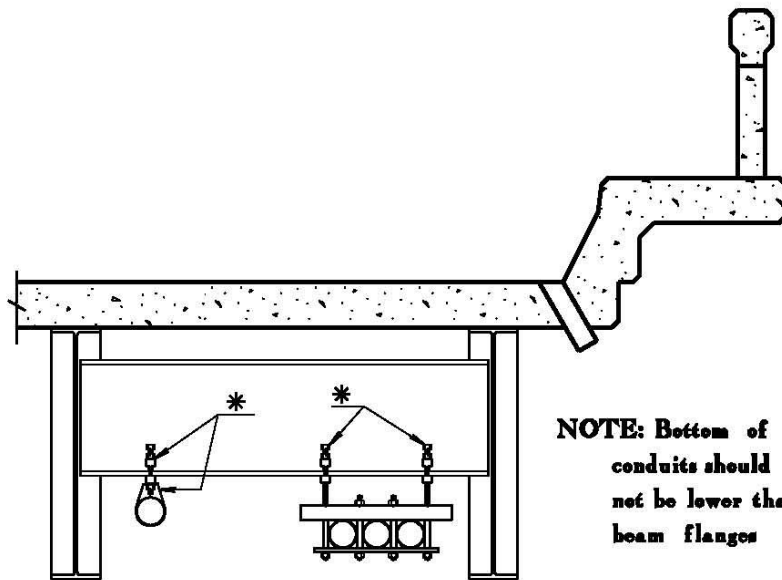

### SINGLE OR MULTIPLE CONDUITS - PREFERRED LOCATION -

(See additional sheet for - ALTERNATE LOCATION -)

\* Drilling, welding, or cutting of any structural steel is not allowed.  
Use Conduit or Beam Clamps in place of drilling or cutting.

**NOTE: All steel materials used in attaching a utility to a structure must be stainless or galvanized.**

# KANSAS DEPARTMENT OF TRANSPORTATION

## UTILITY ATTACHMENT PLACEMENT

For a Steel Superstructure Bridge with cross frame diaphragms

Plot Date : 5/9/2007

View = Plot2

Plotted By : roads

Plot File : W:\Bridge Inspection\B-Schott\Bridg Insp Manuals\Utility Attachments\ultrman.dgn

Support Spacing  
\_\_\_\_\_ meters  
( \_\_\_\_\_ )feet

Diameter Conduit(s)  
\_\_\_\_\_ mm  
( \_\_\_\_\_ )inches

Weight (Includes Conduit,  
Support System and Cables)  
\_\_\_\_\_ kg/ m  
( \_\_\_\_\_ )lbs./ ft.

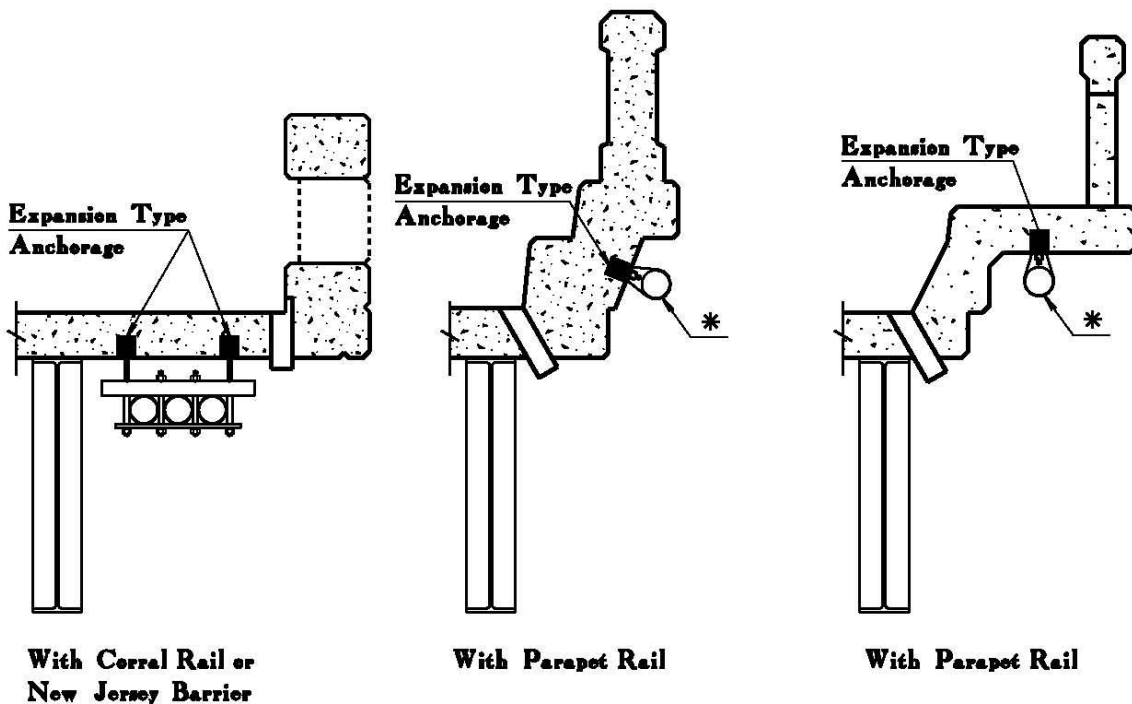

### SINGLE OR MULTIPLE CONDUITS - ALTERNATE LOCATIONS -

\* Drilling, welding, or cutting of any structural steel is not allowed.  
Use Conduit or Beam Clamps in place of drilling or cutting.

**NOTE: All steel materials used in attaching a utility to a structure must be stainless or galvanized.**

Plot Date : 5/9/2007  
View= Plot2  
Plotted By : ranois  
Plot File : WABridge InspectionOfSchoolBridges Insp ManualUtility Attachments\ultramar.dgn

# KANSAS DEPARTMENT OF TRANSPORTATION

## UTILITY ATTACHMENT PLACEMENT

For a Steel Superstructure Bridge with cross frame diaphragms

Support Spacing _____ meters ( _____ )feet	Diameter Conduit(s) _____ mm ( _____ )inches	Weight (Includes Conduit, Support System and Cables) _____ kg/ m ( _____ )lbs/ ft.
--	--	---

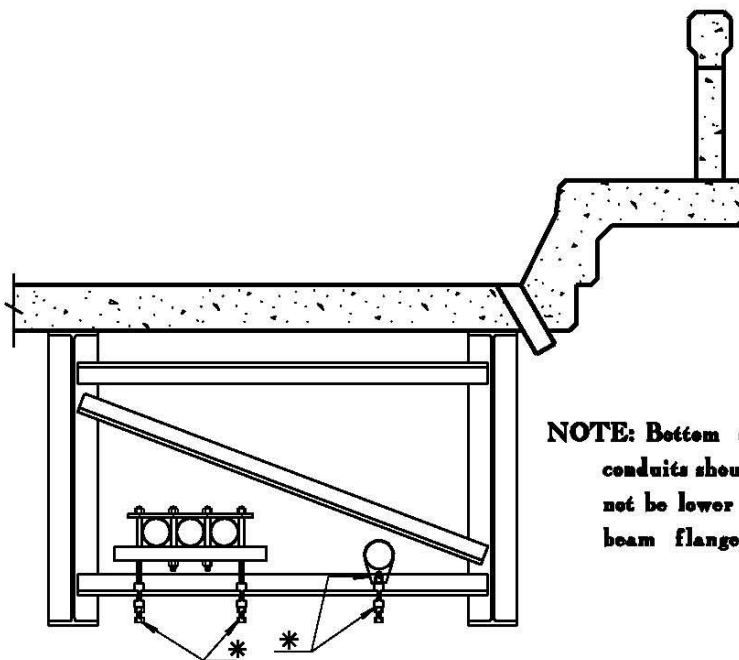

**NOTE: Bottom of conduits should not be lower than beam flanges**

### **SINGLE OR MULTIPLE CONDUITS - PREFERRED LOCATION -**

(See additional sheet for - ALTERNATE LOCATION -)

\* Drilling, welding, or cutting of any structural steel is not allowed.  
Use Conduit or Beam Clamps in place of drilling or cutting.

**NOTE: All steel materials used in attaching a utility to a structure must be stainless or galvanized.**

# KANSAS DEPARTMENT OF TRANSPORTATION

## UTILITY ATTACHMENT PLACEMENT

For Concrete Beam Type Superstructures

Support Spacing _____ meters ( _____ )feet	Diameter Conduit(s) _____ mm ( _____ )inches	Weight (Includes Conduit, Support System and Cables) _____ kg/m ( _____ )lbs./ft.
--	--	--

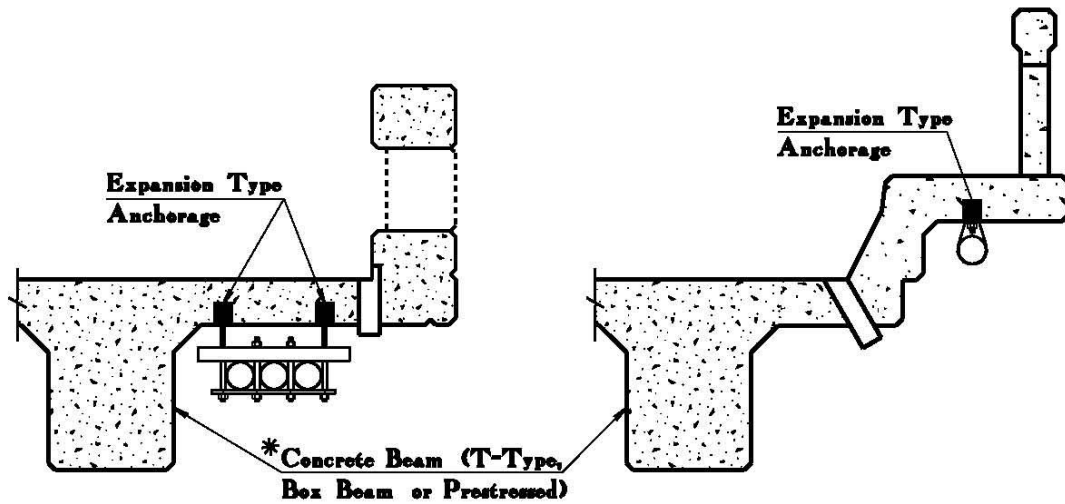

With Corral Rail or  
New Jersey Barrier

With Parapet Rail

**\* NOTE: ATTACHMENT ANYWHERE TO THE CONCRETE SUPERSTRUCTURE (BEAM) WILL NOT BE ALLOWED.**

SINGLE OR MULTIPLE CONDUIT  
- ATTACHMENT LOCATION ON CONCRETE BEAM BRIDGES -

**NOTE: All steel materials used in attaching a utility to a structure must be stainless or galvanized.**

Plot Date : 5/9/2007

View= Plot3

Plotted By : rroads

Plot File : WABridge Inspection\B-School\Bridges Insp Manuals\Utility Attachments\utlman.dgn

# KANSAS DEPARTMENT OF TRANSPORTATION

## UTILITY ATTACHMENT PLACEMENT

For a Concrete Slab Type Superstructure

Support Spacing  
 \_\_\_\_\_ meters  
 ( \_\_\_\_\_ )feet

Diameter Conduit(s)  
 \_\_\_\_\_ mm  
 ( \_\_\_\_\_ )inches

Weight (Includes Conduit,  
 Support System and Cables)  
 \_\_\_\_\_ kg/ m  
 ( \_\_\_\_\_ )lbs./ ft.

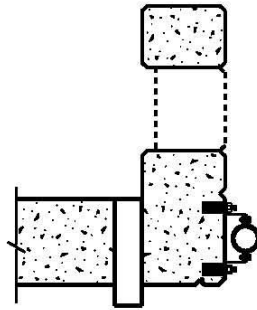

With Corral Rail or  
 New Jersey Barrier

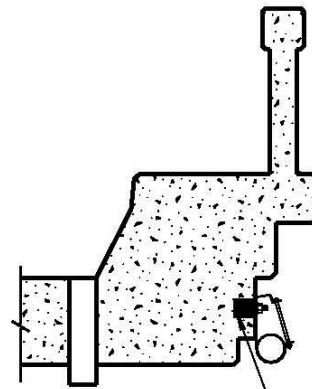

Expansion Type  
 Anchorage

With Parapet Rail

### SINGLE CONDUIT - LOCATIONS -

**NOTE: All steel materials used in attaching a utility to a structure must be stainless or galvanized.**

# KANSAS DEPARTMENT OF TRANSPORTATION

## SOME ACCEPTABLE HANGER & CLAMP TYPES

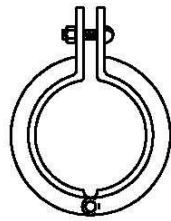

**SPLIT RING  
HANGER**

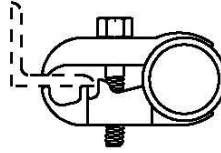

**PARALLEL PIPE AND  
CONDUIT CLAMP**

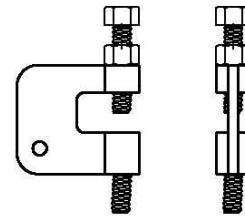

**"C" CLAMP  
WITH LOCKNUT**

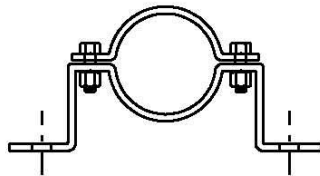

**OFFSET  
PIPE CLAMP**

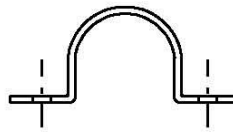

**HOLD DOWN  
PIPE CLAMP**

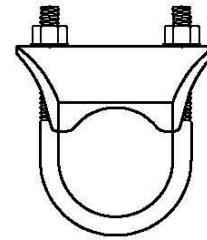

**RIGHT ANGLE  
PIPE CLAMP**

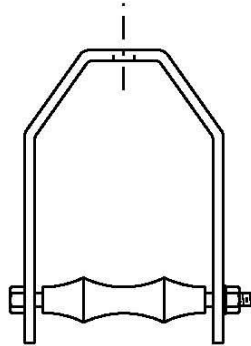

**PIPE ROLLER HANGER**

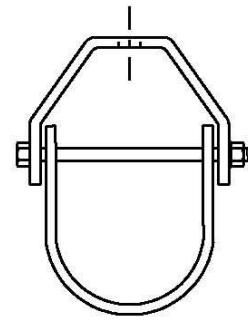

**CLEVIS HANGER**

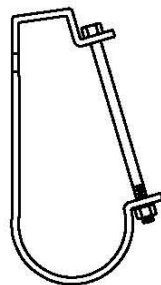

**T-SLOT HANGER**

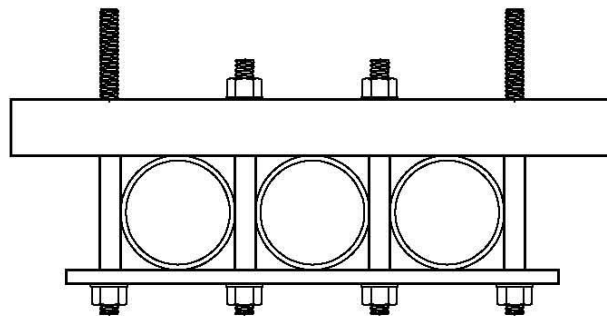

**DUCT SUPPORT SYSTEM**

Plot Date : 5/9/2007

View= Plot+4

Plotted By : ronebis

Plot File : \\NA\Bridg Inspection\B\Schaub\Bridg Insp Manuals\Utility Attachments\ultraman.dgn



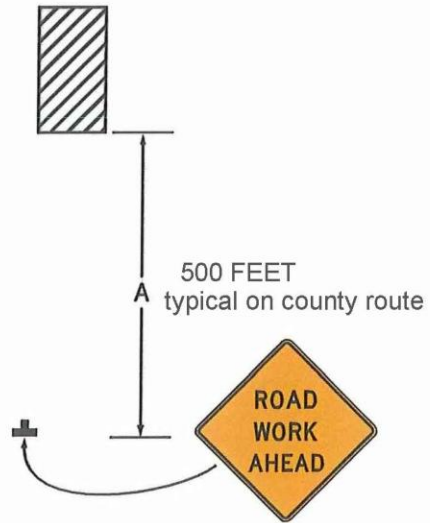
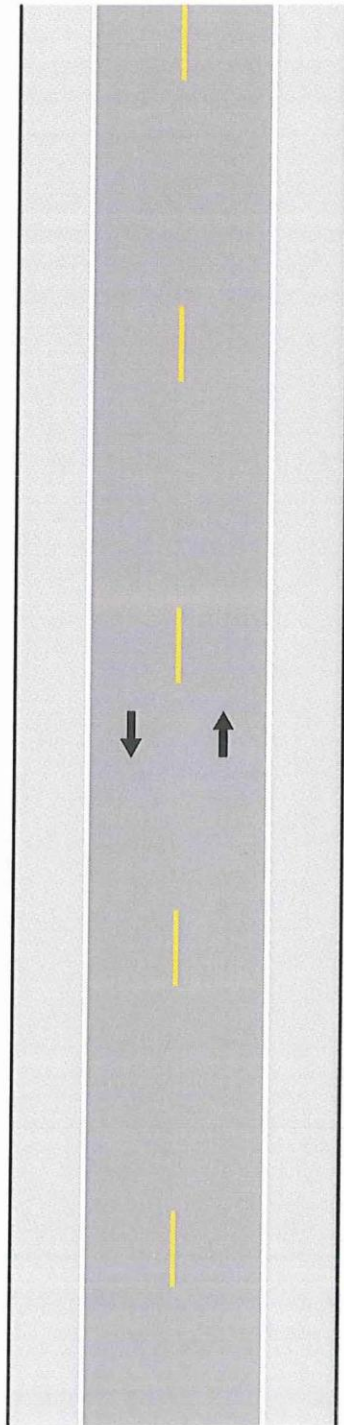

Note: See Tables 6H-2 and 6H-3 for the meaning of the symbols and/or letter codes used in this figure.

**Typical Application 1**



Douglas County Public Works  
 3755 E. 25th Street      Questions? Contact Public Works at  
 LAWRENCE, KANSAS 66046      785-832-5293

TRAFFIC CONTROL  
 TYPICAL APPLICATION 1

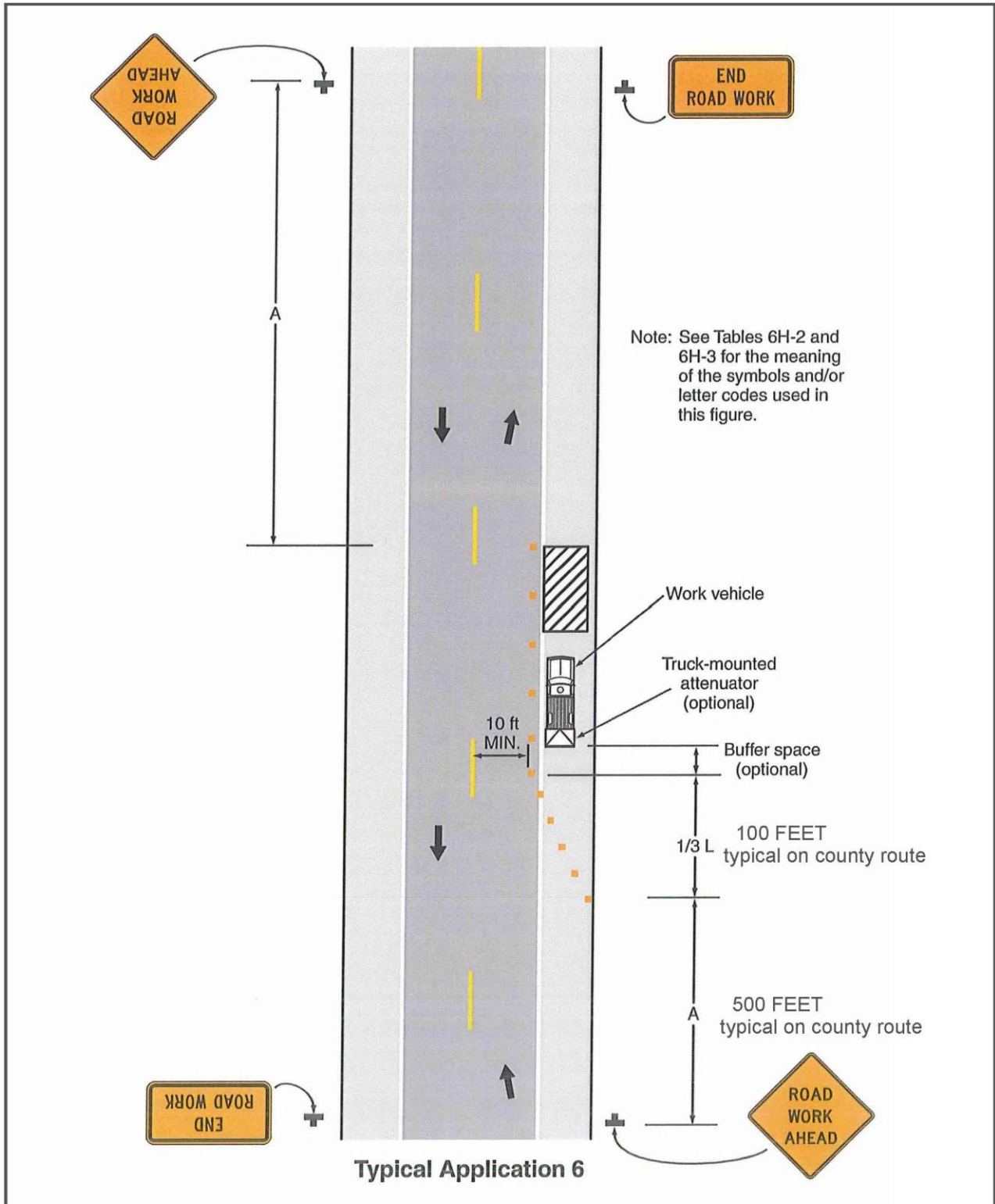

Douglas County Public Works  
 3755 E. 25th Street  
 LAWRENCE, KANSAS 66046

Questions? Contact Public Works at  
 785-832-5293

TRAFFIC CONTROL  
 TYPICAL APPLICATION 6

500 FEET typical on County Route

Note: See Tables 6H-2 and 6H-3 for the meaning of the symbols and/or letter codes used in this figure.

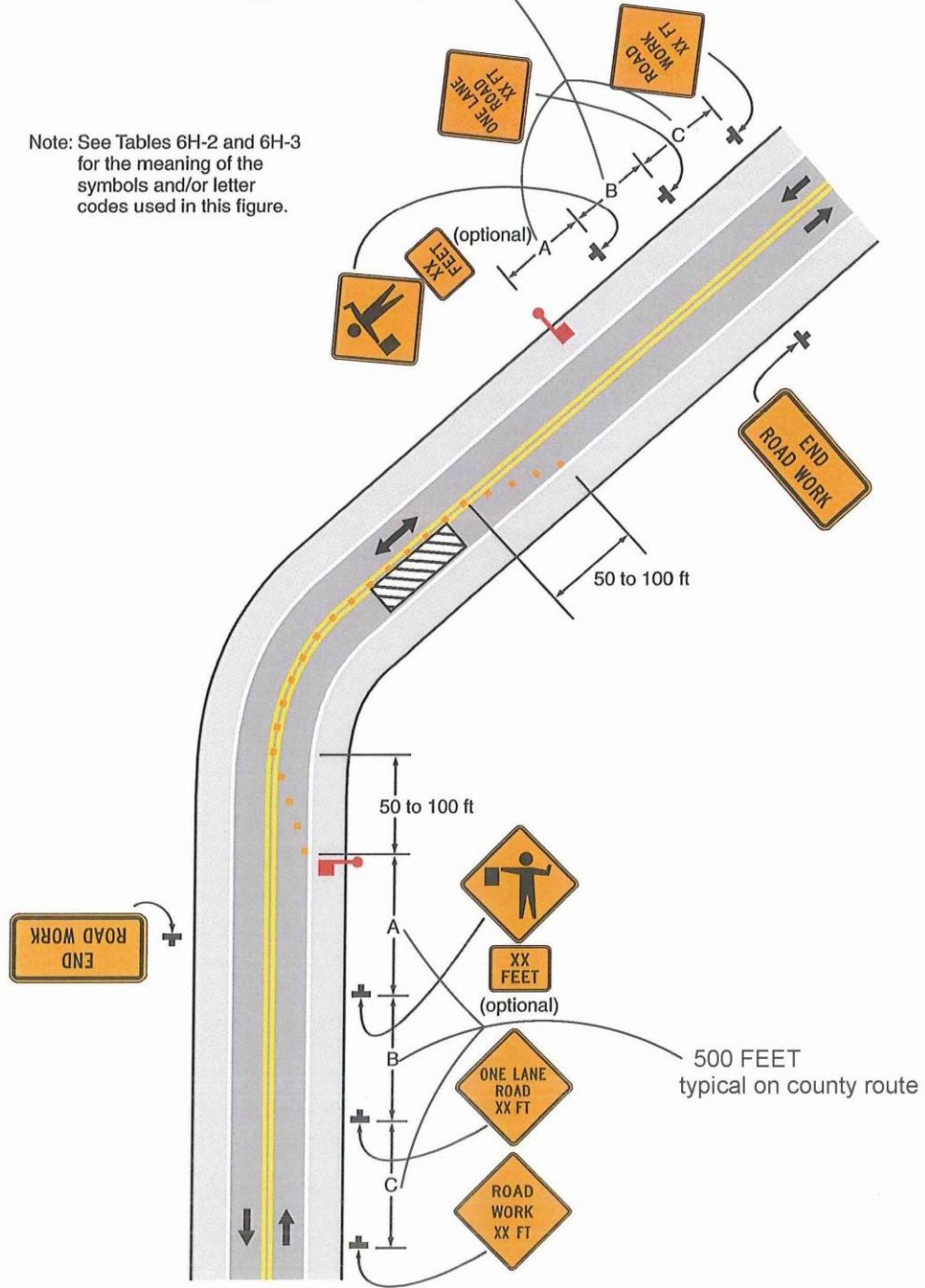

Typical Application 10



Douglas County Public Works  
 3755 E. 25th Street      Questions? Contact Public Works at  
 LAWRENCE, KANSAS 66046      785-832-5293

TRAFFIC CONTROL  
 TYPICAL APPLICATION 10

**Table 6H-3. Meaning of Letter Codes on Typical Application Diagrams**

Road Type	Distance Between Signs**		
	A	B	C
Urban (low speed)*	100 feet	100 feet	100 feet
Urban (high speed)*	350 feet	350 feet	350 feet
Rural	500 feet	500 feet	500 feet
Expressway / Freeway	1,000 feet	1,500 feet	2,640 feet

\* Speed category to be determined by highway agency

\*\* The column headings A, B, and C are the dimensions shown in Figures 6H-1 through 6H-46. The A dimension is the distance from the transition or point of restriction to the first sign. The B dimension is the distance between the first and second signs. The C dimension is the distance between the second and third signs. (The "first sign" is the sign in a three-sign series that is closest to the TTC zone. The "third sign" is the sign that is furthest upstream from the TTC zone.)

**Table 6H-4. Formulas for Determining Taper Length**

Speed (S)	Taper Length (L) in feet
40 mph or less	$L = \frac{WS^2}{60}$
45 mph or more	$L = WS$

Where: L = taper length in feet  
W = width of offset in feet  
S = posted speed limit, or off-peak 85th-percentile speed prior to work starting, or the anticipated operating speed in mph



Douglas County Public Works  
3755 E. 25th Street      Questions? Contact Public Works at  
LAWRENCE, KANSAS 66046      785-832-5293

TRAFFIC CONTROL  
MEANINGS OF SYMBOLS

# INDEX

SUBJECT	PAGE
Abandoned Bored Holes.....	29
Aboveground Utilities.....	23-24
Addresses –DGCO Public Works District and Area offices.....	14
Agreements	
Reimbursable Utility Agreement.....	8, 12-13
Utility Permit Agreement.....	12-13
Appendix.....	38
Application of Policy – General.....	21
Application for Permits.....	13
Attachment to Bridges and Other Structures or Installations near Retaining Wall Systems.....	21
Typical Placement.....	34
Hangers and Clamp Types.....	48
Backfill.....	6, 16, 21-22, 33
Bedding Material.....	22
Boring.....	6, 28-29
Bridge	
Abutments.....	34, 36
Attachments.....	34-36
Brush Control.....	17
Burning.....	18
Casings	
Encasement.....	6, 25-28
Waiver.....	27
Uncased Lines.....	28
Materials.....	29-30
Cathodic Protection.....	29
Change in Ownership.....	12
Chemical Brush Control.....	17-18
Cleanup.....	16-17

## INDEX (Continued)

SUBJECT	PAGE
Clearance	
Horizontal.....	13
Overhead (Vertical).....	13, 33-34
Underground.....	24-26
Clear Zone.....	6-7, 14-15, 18, 21, 23-24, 40
Communication Lines.....	23, 36
Construction Projects.....	5
Crossing Installation	
Aboveground.....	25
Underground.....	25-26
Definitions.....	6-8
Design of Utility Facility.....	15
Dig Safe.....	11
Discharge of Waste.....	12
Disturbed Areas.....	16-17
Drainage Facilities.....	16-17
Ducts.....	26-27
Electric Lines.....	25
Encasement (See Casings)	
Erosion.....	16, 18
Excavation.....	16, 35
Exceptions to Policy.....	23-24, 27
Expansion of Facilities.....	15
FHWA – Approval.....	14
Fiber Optic Cable.....	25, 27
Flaggers.....	14
Gas Lines.....	28
Grout.....	6, 29
Hazardous Materials.....	13, 27, 33, 35

## INDEX (Continued)

SUBJECT	PAGE
Road Permits	
Application.....	13-14
Attachment to Bridges.....	33
Index.....	49-52
Inspection.....	17
Insurance.....	11-13, 33
Liabilities.....	11-13, 17
Location	
General.....	12-14, 16, 21, 24-25
On Structures.....	34
Aboveground Installation.....	23
Underground Installation.....	24
Maintenance and Servicing.....	15-16
Manholes.....	7, 12, 25, 34
Markers.....	12, 22, 25, 27
Materials.....	12-13, 15-17, 22, 26, 35
Non-Compliance.....	12-13
Open Trench.....	26, 28, 35
Overhead Utilities (See Aboveground Utilities)	
Parallel Installations	
Roads	
Aboveground.....	25
Underground.....	25-26
Parking of Vehicles and Equipment.....	15
Permit Revocation.....	11
Pipeline Installations.....	22, 28-29
On Structures.....	33
Cathodic Protection.....	27
Private Utility Lines.....	7, 11, 13, 21, 25
Protection of Traveling Public.....	14-15
References.....	39

## INDEX (Continued)

SUBJECT	PAGE
Reimbursable Utility Agreements (See Agreements)	
Relocation of Utilities.....	13, 16, 21
Restoration of Work Areas.....	16
Right-of-Way Corridors.....	23
Sanitary Sewer Lines.....	27
Seeding.....	16
Settlement of Backfill.....	16
Signs.....	14, 25
Slack Lines.....	23
Spraying Brush.....	17
Storage of Materials.....	15
Structures – Design to Allow Attachments.....	34-35
Telephone Lines.....	21-22, 27
Traffic Control.....	7, 14-15
Trenching.....	21-22, 26
Underground Utilities.....	16, 24-26, 28
Underground Utility Damage Prevention Act.....	12
Utility Corridor.....	26
Utility Permit Agreements (See Agreements)	
Vegetation Protection.....	17
Vents.....	22, 26
Vertical Clearance (See Clearance)	
Waste Material.....	12
Water Lines.....	28, 30
Work Areas (See Disturbed Areas)	